

Managing friction successfully

with SKF and Lincoln automatic wayside and on-board lubrication systems





Thousands of trains around the world operate more reliably and efficiently because of SKF and Lincoln automatic lubrication systems. By delivering precise amounts of lubricant directly to the wheel/rail interface, automatic lubrication systems provide significant benefits in terms of wear, energy and noise reduction.



SKF and Lincoln have joined forces to provide the world's most complete portfolio of lubrication solutions, from manual lubricators to the most advanced centralized and automatic lubrication systems on the market. Together, we provide a full range of lubrication tools and expert services, from turnkey design and installation to testing and training.



Drawing on more than 200 years of combined friction management experience, we can help you improve machine reliability, reduce maintenance costs, improve productivity, enhance safety and optimize manpower resources.

Two leading brands. One global resource.

Leveraging our combined knowledge of lubrication

Why choose SKF and Lincoln lubrication systems? In a word, experience. We have drawn upon our combined knowledge of lubrication and friction management to develop efficient automatic lubrication systems tailored specifically for railway requirements.



SKF knows about complex interrelationships, especially the unique aspects of rail lubrication and friction management. When it comes to equipping railways with high-quality components and

intelligent system solutions, SKF is the ideal partner for wayside and mobile systems to lubricate wheel flanges and to condition rail heads.

For decades, our railroad customers have used SKF and Lincoln lubrication solutions for wayside and on-board applications to increase operating times and lower energy consumption, to improve equipment life and to maximize the return on their investment.

Utilizing our experience and worldwide availability, we work closely with regional and global rolling stock manufacturers, operators and infrastructure owners.

With the combination of Lincoln and SKF lubrication portfolios and capabilities, you now have one go-to resource for best-in-class lubrication services and advanced automatic lubrication systems.



Representing both brands, your local distributor maintains a broad lubrication product offering and is prepared to provide installation or service as



needed. In addition, local market specialists are available to share expertise and support based on specific applications.

SKF and Lincoln – A powerful formula for reliability:

- **Superior product innovation:**
The broadest and most advanced lubrication offering in the industry
- **Unequaled global support:**
Two teams of lubrication experts join forces
- **World-class installation support:**
The combined expertise to install the right solution

To explore our solutions, visit skf.com/TheFormula

A complete portfolio of lubrication solutions to improve reliability

Rail lubrication and friction management

Rail wear has been a challenge for many years in areas of tight curves or heavy loaded tracks. Additionally, in dry weather, the so-called curve screeching or squealing can occur.

The reasons for this are well-known:

One, the wear that occurs between the wheel flange and the outer curve (high rail) causes noise if it is not lubricated.

Two, noise occurs as a result of the so-called stick-slip effect. The longitudinal and lateral micro movements of the wheel on the rail surface cause the wheel to vibrate, resulting in high frequency squealing. This takes place predominately on the inner curve rail (low rail). In addition to noise, the stick-slip effect causes slip waves (wear) on the inner curve rail.

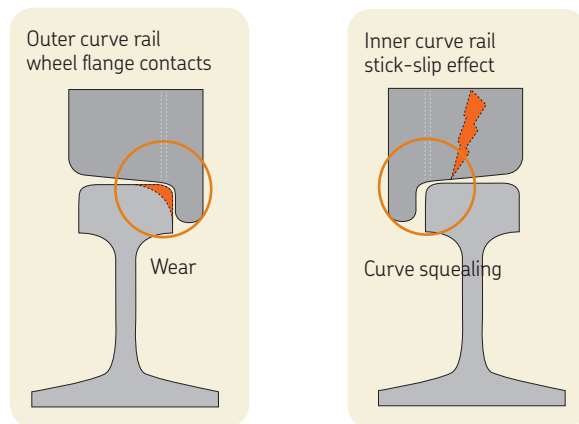

Lubrication can reduce wear and noise, but requires different solutions for different applications. From a tribology point of view, we want to reduce friction and wear at the gauge face/wheel flange; therefore greases are required. For top of rail applications, the goal is to make the longitudinal and lateral sliding more even. To achieve this, we apply so-called friction modifiers or solid particle pastes to the top of the rail. The impact on traction and braking performance is small and comparable to rainy weather conditions.

Complete portfolio from one global source

SKF and Lincoln lubrication systems target the friction and noise occurring at the wheel/rail interface of rail vehicles. SKF offers both wayside and mobile lubrication systems, providing a complete product portfolio to meet customer needs.



Lincoln wayside lubrication systems effectively apply a consistent and controlled volume of lubricant to the rail and hold that grease or friction modifier in place, allowing the wheels to grab and carry it around the track curve. The product range includes solutions for gauge face, top-of-rail and restraining rail.

SKF EasyRail on-board systems for wheel flange lubrication and top-of-rail conditioning are mounted on the first leading vehicle axle. On-board lubrication systems have proven to be very flexible and effective for railway operators due to their variable setting options.



High-viscous lubricants and friction modifiers that are applied automatically and independently from each other help achieve the desired reduction of noise and wear.

SKF offers the industry's most advanced automatic lubrication systems, which are unmatched in their ability to deliver significant benefit for operators under increasing pressure to maximize equipment availability and manage operating costs.

Maximize availability, minimize maintenance tasks and costs

Reduce operating costs

Intelligent technologies to reduce energy, fuel consumption and material wear of rolling stock are gaining acceptance in the railway sector. The American Association of Railroads (AAR) estimated that the wear and friction occurring in the wheel/rail interface of trains due to ineffective lubrication costs railway operators in excess of \$2 billion (U.S.) each year.



SKF and Lincoln automatic lubrication systems deliver small, measured amounts of lubricant precisely when needed. On-board systems lubricate the wheel flange, and wayside systems lubricate the rail as the train is passing. This combined approach increases system reliability and reduces lubricant consumption.

Maximize availability

Reliably delivering lubricant or friction modifiers, SKF and Lincoln automatic lubrication systems help prevent material damage at wheels and rails, while optimizing manpower resources.

Maintenance benefits

- Reduces labour costs
- Extends repair intervals
- Reduces lubricant consumption

Operational benefits

- Increases equipment reliability
- Reduces unplanned downtime
- Reduces energy and fuel consumption
- Improves equipment profitability

Safety benefits

- Eliminates manual lubrication of difficult-to-access points
- Reduces the risk of derailments

Environmental benefits

- Reduces noise
- Eliminates over-lubrication

Improve wear reduction

Industry studies have shown that operators can double wheel life by maintaining proper wheel flange lubrication. Furthermore, utilizing wayside lubrication can extend rail life up to three to six times longer by reducing wear. This results in reduced operating and maintenance costs.

Reduce energy and fuel consumption

Studies indicate that you can save up to 8 percent in fuel consumption of loaded trains when using proper lubrication and protection against wear and stick-slip effect.

Experience in a wide range of rail applications

Equipped with broad experience in managing lubrication tasks, SKF has the right system for your specific rail application. Based on a detailed project analysis, which takes infrastructure, rolling stock and environmental conditions into consideration, our engineers determine the appropriate lubrication system for your needs. In many cases, a combination of wayside and on-board lubrication systems are recommended.



Wayside lubrication systems

In Lincoln's wayside systems for gauge face lubrication and top-of-rail conditioning, passing trains are detected by track-mounted wheel sensors. The applied lubricant is picked up by passing wheels.

High-pressure, low-volume pumps effectively cover the rail with just enough lubricant, minimizing waste. A wiper bar with an integrated progressive metering device applies the lubricant or friction modifier directly to the gauge face or top-of-rail. Lincoln's progressive pump-to-port technology (PTP) enables exact metering of grease, helping to ensure each lube port receives the same small amount of grease every time, automatically.



The systems are capable of pumping long distances, as well as high-viscosity lubricants. Dual track systems and customized solutions are available.



Advantages:

- Free track survey to pinpoint trouble spots
- “No-clog” lubrication via high-pressure pumps
- Exact metering of grease
- Cost-effective, combined gauge face and top-of-rail system layouts possible

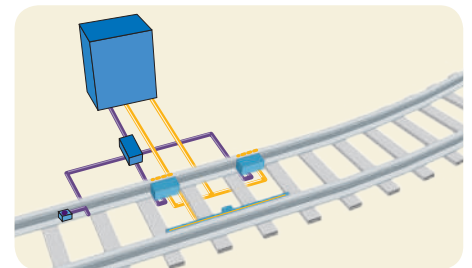

Systems:

- Gauge face lubrication (GF)
- Top-of-rail conditioning (TOR)
- Restraining rail lubrication
- Combination of GF and TOR

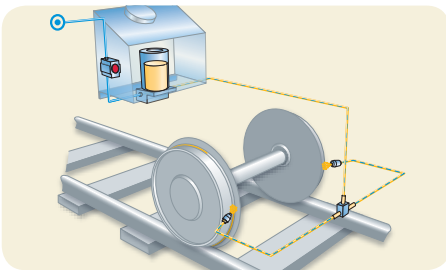

On-board lubrication systems

SKF EasyRail wheel flange lubrication and top-of-rail conditioning systems are mounted on-board on the first leading vehicle axle. When activated, air and lubricant are fed from the grease tank to the spray nozzle. The lubricant is sprayed to the wheel flange in a thin layer and transferred to the gauge face of the rail by direct contact.

SKF EasyRail systems can be configured for single- and dual-line lubrication system applications, for high and low pressure. SKF EasyRail Airless is available for vehicles without on-board air supply.

All SKF EasyRail systems also are available as top-of-rail conditioning systems in which the nozzles apply the friction modifier directly to the top of the rail. They require low maintenance and operate reliably even under extreme climatic conditions.

Systems:

- **Single-line wheel flange lubrication systems for railway vehicles:**
 - SKF EasyRail Compact
- **Dual-line wheel flange lubrication systems for railway vehicles:**
 - SKF EasyRail Low-Pressure
 - SKF EasyRail High-Pressure
- **Automatic lubrication systems for applications without air supply:**
 - SKF EasyRail Airless

Advantages:

- High reliability
- Exact metering
- Demand-driven activation (curve, time or distance dependent)
- No mechanical contact between lubrication system and wheel (compared to stick lubrication)
- Easy maintenance



Wayside lubrication – the method of applying lubricant makes the difference

Gauge face lubrication

Lincoln's lubrication system places the grease high on the gauge face so it can be carried by passing wheel flanges. One gauge face system can supply several curves in succession. A brush holds excess grease to be picked up by the next train, which minimizes grease waste.



Wiper bars have an integrated progressive metering

device that equally meters the lubricant to 12 outlets which apply the lubricant evenly on the gauge face of the rail. Lincoln's pump-to-port technology helps to ensure that each port receives the same volume of grease.

The high-pressure system helps to ensure grease delivery in cold temperatures and automatically keeps ports open and free of debris.



A universal mounting bracket easily adjusts to install the wiper bar on most rail sizes. Bars can be dismantled by simply removing two bolts and one hose, allowing for easy reinstallation after rail grinding.

Top-of-rail (TOR) protection

Depending on the friction modifier, one Lincoln top-of-rail protection system can support track curves up to 500 m (550 yd). Longer curves need to be managed by additional systems. Two types of applicators are available:



A Single-Line Injection Device (SLID) applies the friction modifier after the train passes in anticipation of the next train. A SLID, which can be mounted from inside or outside the rail, applies the modifier without making contact with the rail or wheel. It comes with an integrated heating system for reliable operation in low temperatures and also can be used for gauge face lubrication.

The Contact Applicator is capable of applying friction modifier to the outer side of the rail as the train passes the site. Using progressive pump-to-port technology helps to ensure the same volume of lubricant is delivered to each port. The bar is mounted from the field side to the rail. Because the bars are spring mounted, they withstand false-flange wheel strikes.



Restraining rail systems



Restraining rails exist to support trains from derailing in curved-track situations and switches. One wheel of an axle is guided on both sides so that the outside flange on the high rail side makes contact with the restraining rail. However, the friction

from the contact creates high noise emission. Lincoln's restraining rail lubrication system reduces wear and noise emission.

Mounting hardware for the restraining rail, like the gauge face bar, is designed for easy installation and removal for track maintenance. Its low-profile design reduces wheel strikes.

The system utilizes pump-to-port technology to dispense the precise volume of lubricant to each port. The system's high-pressure capability helps to ensure reliability even in cold temperatures.



Rail lubrication through lubrication holes

In comparison to mainline trains, the tracks of trams and metros are not as highly loaded, which is why lubricant channels drilled into the rails are the preferred choice to apply lubricants. Nevertheless, the customer needs to approve this method in consultation with local traffic authorities.

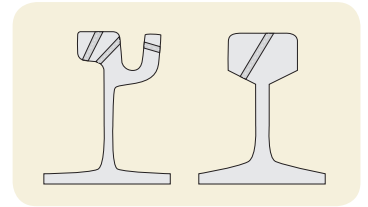

The lubricants or friction modifiers are brought to the lubrication point via high-pressure hoses. The number and position of the channels are determined on site, helping to ensure

that the wheels are actually in contact with the lubricant.

System options to meet customer requirements include aboveground and underground pump stations, steelboxes to protect the hose connections, ultrasonic train sensors, axle count sensors and more.

Drilling is performed by our trained personnel with appropriate tools during the installation of the system.



The right components for every wayside system

System components:

- **Pump station:**
 - Pump
 - Reservoir
 - Controller
- **Wheel/Axle counter sensor**
- **Lubricators:**
 - Wiper bar with integrated progressive metering device
 - SLID
 - Contact Applicator
 - Lubrication holes, served by progressive or single-line metering devices
- **Power supply:**
 - Standard electrical connections (24 V DC; 220/400 V AC)
 - Solar power panels

Optional components:

- Electrically monitored progressive metering device
- Cabinet heater
- Rain sensor
- Pump station door sensor
- External signal lamp to indicate system needs attention
- Solar unit with battery storage
- Remote monitoring



Comprehensive range of pump stations

The choice of pump and reservoir depends on the application and is determined by the lubricant consumption and the amount of traffic. Additionally, maintenance routines and intervals should be taken into consideration. For wayside rail lubrication and conditioning systems, SKF offers drum, multi-line and reservoir pumps.

The Lincoln FlowMaster pump is a high-pressure, drum pump proven in harsh industrial applications. It is the standard pump for gauge face, TOR and restraining rail. The FlowMaster is available with different reservoir sizes, from 25 kg (55 lb.) hobbicks, a 90 kg (200 lb.) metal reservoir, up to the 363 kg (800 lb.) standard reservoir. Custom reservoir sizes are available upon request. All reservoirs support environmental safety and are easy to access, transfer and install.

For compact rail lubrication systems that are intended for minimal consumption, reservoir pumps come into play. They also are used in rail head conditioning systems, especially in municipalities with public rail transport. These pumps come with reservoirs up to 20 kg (44 lb.). These types of pumps typically are mounted, along with control and monitoring devices, in a cabinet designed for use in low working temperatures.



Remote monitoring

Many wayside lubrication systems operate in remote locations. SKF has developed different options to monitor function and filling level of those systems. The simplest option is to send a low-level warning message via SMS to the operator. E-mail messaging also is possible. In addition, the operator can send messages to the unit, for instance to query the tank level or to turn off the lubricator. The most advanced option is to send operational data via GSM Module to a web-based system.



Controllers

SKF offers a wide range of controllers that can be customized to your application: from simple time-controlled units integrated into reservoir pumps, to high-technology digital devices that precisely control the amount of lubricant applied to the rail. These digital controllers also offer the adjustment of run-time monitoring, metering device cycles and number of axles.



Wheel/Axle counter sensors

A robust design protects the sensors against damage from debris or ice. The non-contacting, magnetic flux sensors are mounted in a protected location below the rail head, out of the path of wheel flanges.



Metering devices

Lincoln's SSV progressive metering devices incorporate a series of metering pistons which accurately dispense lubricant from each outlet, overcoming back pressure of up to 300 bar (4 000 psi). Versions with lube ports ranging from six to 22 are available. The devices can be protected in a cabinet.

SKF's VR single-line metering devices are high-precision components which provide very small amounts of lubricant. They feature high-pressure resistance up to 315 bar (4 560 psi). Every lubrication point can be visually monitored using indicator pins.



Solar panels

The solar panel is designed to provide 20-plus years of life in extreme temperatures and low-light conditions. The solar controller ensures a proper battery charge and disables the system if the batteries reach an unsafe level.



SKF EasyRail – Intelligent mobile lubrication systems

SKF EasyRail Compact



The system can be used universally on all vehicle segments from urban transport to regional and intercity trains, as well as locomotives.

SKF EasyRail Compact operates through homogenous lubricant metering, the dosage is defined at the pump unit. Compressed air is used as a transport medium. The lubricant moves along the pipe system via a flow divider towards the spraying nozzles, where the lubricant is evenly distributed on the wheel flange.

SKF EasyRail Compact works with a system air pressure up to 10 bar (145 psi). It is compatible with oil and fluid grease containing up to a certain percentage of solid additives.

The ease of installation also allows quick retrofitting on existing rail vehicles. The lines between the grease reservoir and spray nozzle can be 7 m (8 yd) long at a maximum.

System components:

1. Pneumatically operated piston pump with lubricant reservoir
2. Actuation via valve unit
3. Spray nozzles
4. Control unit and curve sensor (option)
5. Flow divider

LCG2 – Control and curve sensing for every SKF EasyRail system

The intelligent control unit LCG2 effectively manages the lubrication needs of the operator and reduces lubricant consumption to a minimum. A built-in gyro sensor detects the angular speed of the yaw axis which allows curve sensing. Sensitivity can be configured by the customer individually.

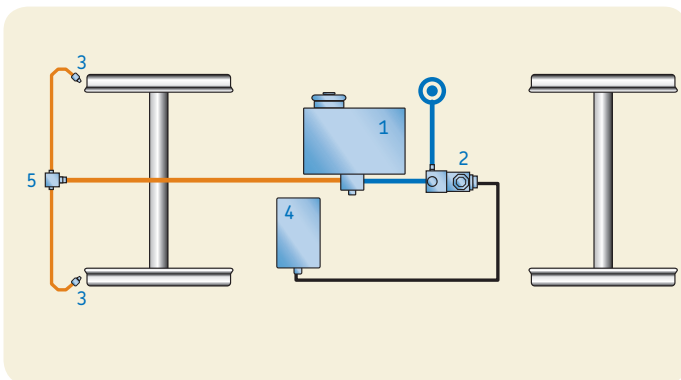

System layout to lubricate both wheels at once

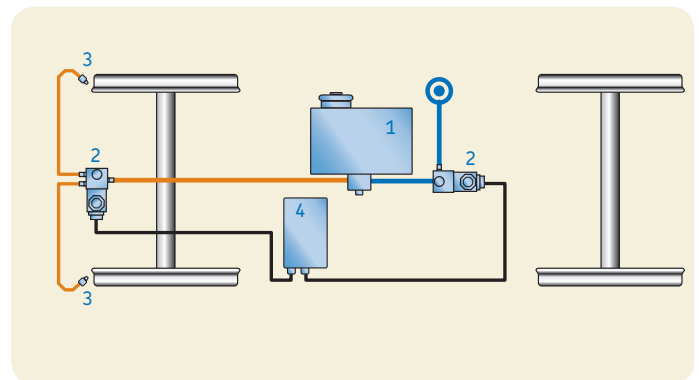

System layout to lubricate the left and the right wheel separately

SKF EasyRail Airless



On tramway or light rail vehicle systems and metros where compressed air supply is not available, SKF EasyRail Airless systems should be considered.

Depending on the application conditions, these systems are well suited to be used for wheel flange lubrication as well as top-of-rail conditioning. The lubricant is applied in a defined quantity without the use of compressed air.

An SKF KFG piston pump serves as lubricant reservoir and recirculation unit to feed a ring line providing the lubricant to electromagnetic pumps. SKF's electromagnetic PER pumps may be installed in any suitable space of the bogie above the rail. They are equipped with two nozzles for wheel flange lubrication and one single nozzle for top-of-rail conditioning, applying the friction modifier vertically to the top of the rail precisely and in a predefined quantity.

Each pump-nozzle unit is equipped with a heating system to facilitate the delivery of lubricant even under cold weather conditions. Depending on operational requirements, three different nozzle designs that are adjustable can be installed. Customized solutions are available upon request.

System components:

1. Electrically operated piston pump unit with lubricant reservoir
2. Electromagnetic distribution pump:
 - With one or two spraying nozzles,
 - Three different nozzle designs allow for three different dosages
3. Control unit and curve sensor (optional)

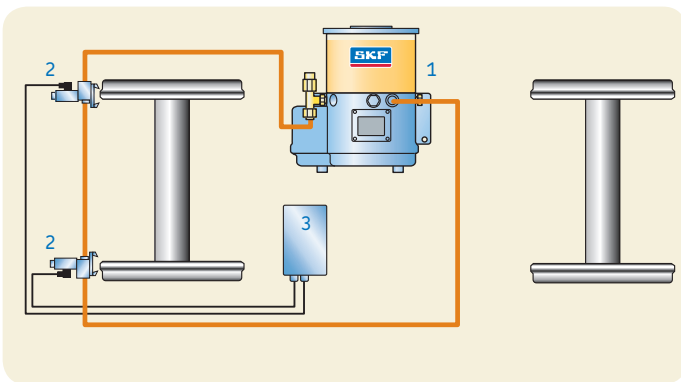

System layout for wheel flange lubrication

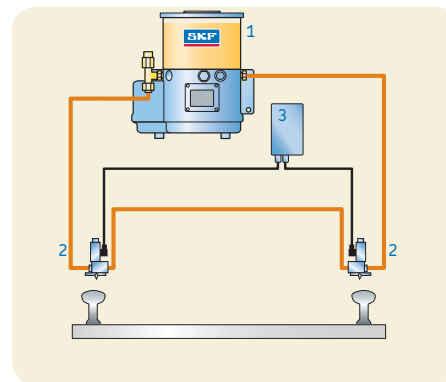

System layout for TOR conditioning

SKF EasyRail Low-Pressure



These systems can be used on all vehicle segments from urban transport to regional and intercity trains as well as locomotives.

The ease of installation also allows quick retrofitting on existing rail vehicles. The SKF EasyRail Low-Pressure system transports compressed air and the lubricant in separate lines and meters the lubricant directly inside the spray nozzle.

The continuous compressed air supply for the pressure reservoir is enabled when the rail vehicle is made operational. The system pressure can be up to 10 bar (145 psi). The lubricant is metered inside the spray nozzles and applied with high accuracy onto the wheel flanges.

SKF EasyRail Low-Pressure systems allow flexible installation (horizontal/vertical) with a maximum line length of 5 m (5,5 yd) between the pressurized reservoir and spray nozzle. The pressurized reservoir is customized to capacities of 4,5 and 6 litres (1,2 and 1,6 US gal lqd.)

System components:

1. Pressure reservoir
2. Actuation via valve unit
3. Spray nozzles
4. Control unit and curve sensor (optional)

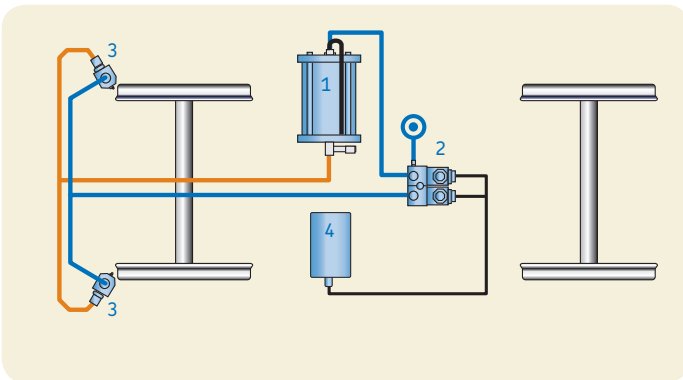

System layout to lubricate both wheels at once

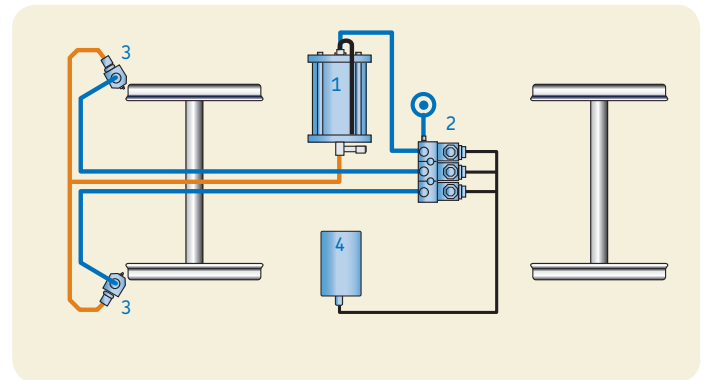

System layout to lubricate the left and the right wheel separately

SKF EasyRail High-Pressure



These dual-line lubrication systems are mainly used on large locomotives, high-speed trains with power heads, but also other applications that require a lubricant

reservoir bigger than seven litres (1,8 US gal lqd) for maintenance reasons.

The SKF EasyRail High-Pressure system can be customized as a centralized lubrication unit for bi-directional operations. It is a single-pump solution for vehicles with a maximum of 20 m (788 in.) distance between the wheelsets that need to be sprayed.

The SKF EasyRail High-Pressure system transports compressed air and lubricant in separate lines and meters the lubricant directly inside the spray nozzle.

The system pressure can be up to 100 bar (1 450 psi). The lubricant is metered inside the spray nozzles and applied with high accuracy onto the wheel flanges. The high system pressure allows maximum line lengths of 10 m (11 yd) between pump unit and spray nozzle.

The system features enable reliable lubricant application at extreme speed and/or environmental conditions, including temperatures as low as $-40\text{ }^{\circ}\text{C}$ ($-40\text{ }^{\circ}\text{F}$) with suitable lubricants.

System components:

1. Piston pump with reservoir
2. Actuated via valve unit
3. Spray nozzles
4. Control unit and curve sensor (optional)
5. Grease control valve

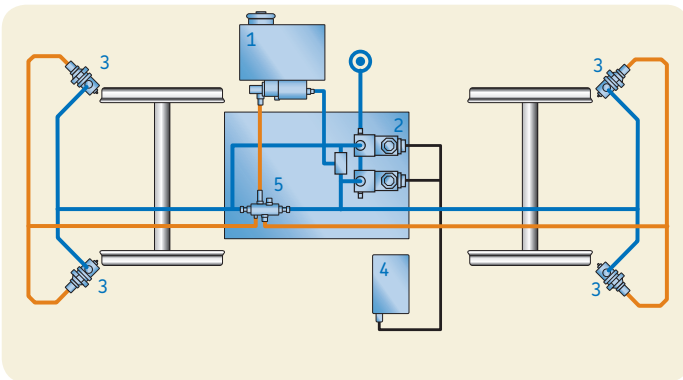

System layout to lubricate both wheels at once

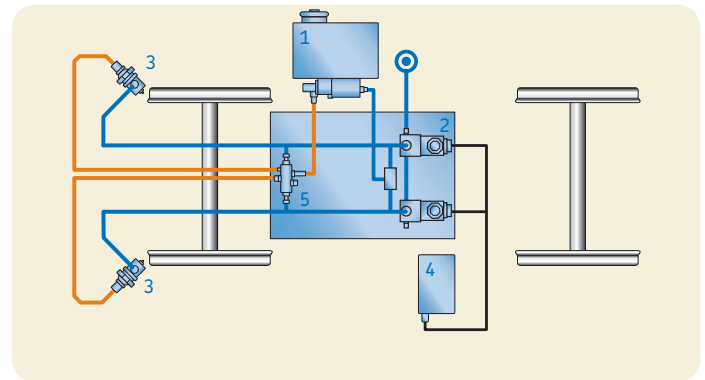

System layout to lubricate the left and the right wheel separately

The right system for your application

Our engineers and distributors are ready to support you and to configure the right system for your application. Review the diagram and table on this page as a guideline to determine which system might accommodate your infrastructure or rolling stock.

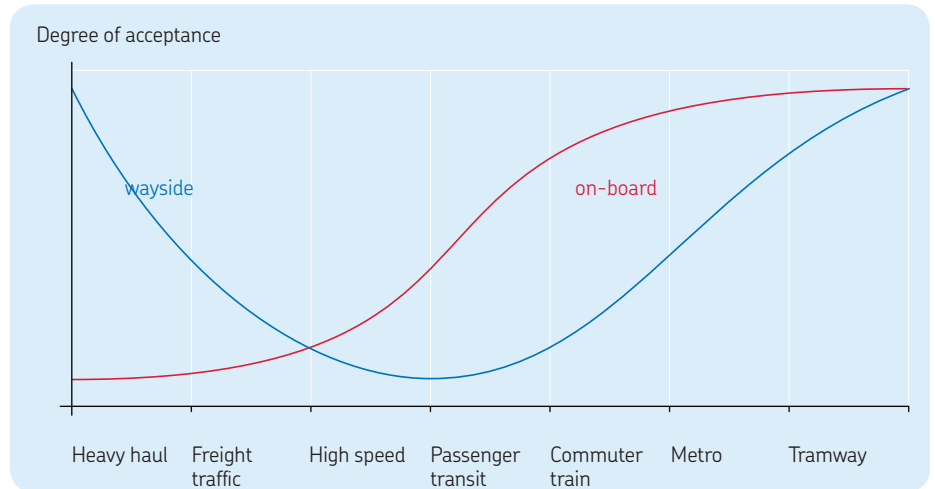

Lubrication system	Rail application						
	Heavy haul	Freight traffic	High-speed	Passenger transit	Commuter train	Metro	Tramway
Wayside lubrication with							
Gauge face lubrication (GF)	•						
Top-of-rail conditioning (TOR)		•					
Restraining rail lubrication			•				
Wheel flange lubrication (WFL)							
Wiper bar	•	•		•	•	•	
Contact Applicator		•					
Restraining rail lubricator	•	•		•	•	•	
SLID	•	•		•	•	•	•
Lubrication holes	•	•				•	•
Onboard lubrication							
EasyRail Airless		•				•	•
EasyRail Compact		•			•	•	•
EasyRail Low-Pressure		•			•	•	•
EasyRail High-Pressure		•	•		•	•	•

World-class installation support

Representing both brands, your local distributor maintains a broad lubrication product offering and is prepared to provide installation or service as needed. Whatever your application, we have the experience, the knowledge and the lubrication products to minimize wear, maximize availability and to keep your stock rolling.



Service solutions from SKF



Electronic CAD product catalog

3-D CAD data is available in native format in the online product catalog, which is based on the eCATALOGsolutions technology by CADENAS GmbH. You can configure your products online from the centralized lubrication area and integrate them into your design process free of charge. You can integrate the CAD data seamlessly into your layout plans. The SKF LubCAD app allows you to use the SKF CAD download portal for lubrication systems with its full functionality for your mobile devices.

Access our online catalogue at <http://skf-lubrication.partcommunity.com>



Retrofitting centralized lubrication systems

Maintenance and repair costs during system downtime can quickly become unwieldy. That is why we offer on-site, professional retrofitting of centralized lubrication systems at your location. We also can assume responsibility for maintenance and repair during ongoing operations.

In addition, our portfolio includes other solutions that may make maintenance easier for you, from an electric refilling pump to appropriate fittings and accessories.



Procurement logistics and synchronized production

SKF can tailor its logistics processes to the requirements of our customers. For example, using synchronized electronic KANBAN systems with first-in, first-out logistics, we enable an inventory-free supply for manufacturing and assembly that is synchronized with production.

As a result, run-through times and total outlays are improved, and the risk of loss and damage is reduced. This results in optimum supply chain management, whether your needs are exclusively local or global.

Global experience, global support

More than 200 years of combined SKF and Lincoln experience

By uniting the worldwide experience, portfolios and distribution networks of the SKF and Lincoln brands, we offer the industry's most complete range of lubrication management solutions across the globe.

Whatever the size or design of your machines, SKF has the products and resources to help you increase bearing life, machine uptime and safety, while minimizing manpower hours, maintenance costs and environmental impact.

A network of experienced partners

SKF- and Lincoln-branded products, systems and services are available through a global network of distributor partners, supported by one unified sales organization committed to your success. System house distributors around the world offer turnkey solutions and extensive aftermarket support. In addition to maintaining a local inventory of system components and spare parts, these factory-trained lubrication specialists can provide:

- **Customized lubrication system design**
- **System installation and start up**
- **Service and repair**
- **Lubrication analysis and testing**
- **Lubrication management training**
- **Warranty support**
- **System maintenance contracts**
- **Surveys and recommendations**
- **Return-on-investment (ROI) analysis**
- **Guidance on safety and environmental issues**
- **Pre-assembled lubrication kits for easy retrofitting**



Here for you, wherever you are

With lubrication application centres located on every continent and a worldwide distributor network, SKF has the people, products and support you need to optimize your lubrication management programme.

For more information, contact your SKF representative or visit [skf.com/TheFormula](https://www.skf.com/TheFormula).

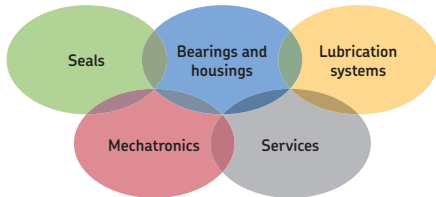

The Power of Knowledge Engineering

Combining products, people, and application-specific knowledge, SKF delivers innovative solutions to equipment manufacturers and production facilities in every major industry worldwide. Having expertise in multiple competence areas supports SKF Life Cycle Management, a proven approach to improving equipment reliability, optimizing operational and energy efficiency and reducing total cost of ownership.

These competence areas include bearings and units, seals, lubrication systems, mechatronics, and a wide range of services, from 3-D computer modelling to cloud-based condition monitoring and asset management services.

SKF's global footprint provides SKF customers with uniform quality standards and worldwide product availability. Our local presence provides direct access to the experience, knowledge and ingenuity of SKF people.

® SKF and EasyRail are registered trademarks of the SKF Group

® Lincoln is a registered trademark of Lincoln Industrial Corp.

© SKF Group 2014

The contents of this publication are the copyright of the publisher and may not be reproduced (even extracts) unless prior written permission is granted. Every care has been taken to ensure the accuracy of the information contained in this publication but no liability can be accepted for any loss or damage whether direct, indirect or consequential arising out of the use of the information contained herein.

PUB LS/S2 14824 EN · July 2014 · **1-2024-EN**

This publication supersedes publications PUB LS/P2 13163 EN, PUB LS/P2 13193 EN, PUB LS/P2 13205 EN.

Certain image(s) used under license from Shutterstock.com